

A robust AVR-PSS synthesis using genetic algorithms (Implementation under GUI/MATLAB)

GHOURAF Djamel Eddine¹, NACERI Abdellatif¹, KABI Whiba¹ and HORCH Abdessamed¹

¹Department of Electrical Engineering University of SBA

IRECOM Laboratory

BP 98 22000 Algeria

E-mail: jamelbel22@yahoo.fr

Abstract— This paper presents the use of genetic algorithms (GA) to synthesize the optimal parameters of Power System Stabilizer (PSS), this later is used as auxiliary of turbo generator excitation system in order to damp electro mechanicals oscillations of the rotor (inductor), and consequently, improve the Electro Energetic System (EES). In this study we started with the linearization of a system around the operating point, then we analyzed its stability in slight movement after that, we have optimized the PSS parameters using the Genetic Algorithms (G.A). The obtained results have proved that (G.A) are a powerful tools for optimizing the PSS parameters and more robustness for the studied power system (PS). Our present study was performed using a GUI realized under MATLAB in our work.

Keywords— AVR-PSS, power system, genetic algorithm, GUI-MATLAB, powerful synchronous generators, stability and robustness.

I. INTRODUCTION

The electric power system (EPS) stability is viewed as the most necessary condition to regular operating electrical network control systems are required to ensure this stability by identifying the main factors that influence on this one. The Classical controllers automatic voltage regulator (AVR) and power system stabilizer (PSS) [1,2] (PI or PID) have a leading role in increasing static and dynamic stability degree, and damping electro mechanicals oscillations generated by the rotor (the inductor). However, a robustness test (a disturbance injected on the EPS) showed that PID-AVR and PSS are hardly robust, so, in order to improve their efficiency (robustness), we used the (G.A) for the optimization and the adjusting of PSS parameters [3,4].

The genetic algorithms is a global research technical and an optimization procedure based on natural inspired operators such as crossing, and selection [5,6]. Unlike other optimization methods, the (G.A) operate under several encodings parameters (binary, ternary, real...), to be optimized and not the parameters themselves. In addition, to better guide the AVR-PSS optimal parameters search, the (G.A) use a performance index to approach this solution [6].

II. DYNAMIC POWER SYSTEM MODEL:

In this paper the dynamic model of an IEEE - standard of power system, namely, a single machine connected to an infinite bus system (SMIB) was considered [4]. It consists of a

single synchronous generator (turbo-Alternator) connected through a parallel transmission line to a very large network approximated by an infinite bus as shown in figure 1.

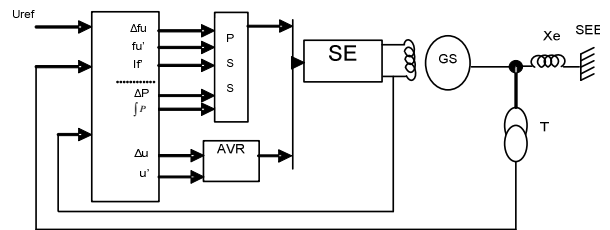

Fig. 1. Standard system IEEE type SMIB with excitation control of powerful synchronous generators

The automatic voltage regulator (AVR), is a controller of the SG voltage that acts to control this voltage, through the exciter. Furthermore, the PSS was developed to absorb the generator output voltage oscillations [5].

In our study the synchronous machine is equipped by a voltage regulator model "IEEE" type - 5 [7, 8], as is shown in Figure 2.

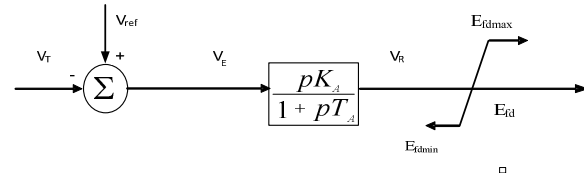

Fig. 2. A simplified "IEEE type-5" AVR

$$V_R = \frac{K_A V_E - V_R}{T_A}, \quad V_E = V_{ref} - V_F \quad (1)$$

About the power system stabilizer (PSS), considerable's efforts were expended for the development of the system. The main function of a PSS is to modulate the SG excitation to [1, 2, 4].

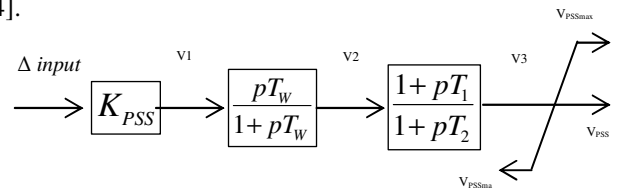

Fig. 3. A functional diagram of the PSS used [8]

In this paper the PSS signal used, is given by: [14]

$$\begin{aligned} \dot{V}_1 &= \frac{V_2 - V_1}{T_1} + \frac{T_2}{T_1} \dot{V}_2 ; \\ \dot{V}_2 &= \frac{V_3 - V_2}{T_2} + \frac{T_3}{T_2} \dot{V}_3 ; \\ \dot{V}_3 &= \frac{V_3}{T_w} \dot{V}_1 ; \dot{V}_1 = K_{PSS} \Delta input \end{aligned} \quad \Delta input = \begin{cases} \Delta P, \int P \\ \text{or} \\ \Delta \omega = \omega_{mach} - \omega_0 \\ \text{and} \\ \Delta I_f = I_f - I_{f0} \\ \text{and} \\ \Delta U_f = U_f - U_{f0} \end{cases} \quad (2)$$

III. THE GENETICS ALGORITHMS THEORY

A. Introduction

Overall, a Genetic Algorithm handles the potential solutions of a given problem, to achieve the optimum solution, or a solution considered as satisfactory. The algorithm is organized into several steps and works iteratively. The figure 4 shows the most simple genetic algorithm introduced by Holland [6].

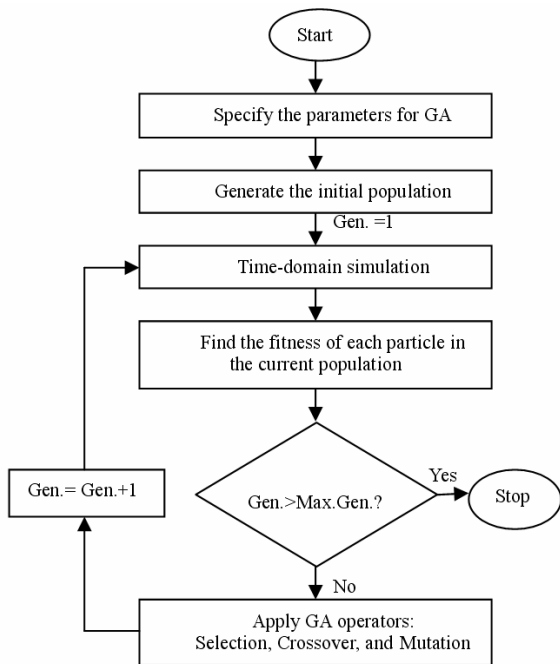

Fig. 4. The genetic algorithm organization

B. The genetic algorithm steps description

In what follows, we will describe in more detail the various steps of a simple genetic algorithm Figure 4

1) Coding and initialization [9]

The first step is the problem parameters coding in order to constitute the chromosomes. The most used type of coding is the binary one, but other coding can be also used for example: ternary, integer, real...the passage from the actuary representation to the coded one is done through encoding and decoding functions.

2) Evaluation

It's to measure the performance of each individual in the population; this is done using a function directly related to the objective function which is called "fitness function". This is positive real function that reflects the strength of the individual. An individual with a high fitness value is a good solution to the problem, whereas individual with low fitness value represents a worse solution.

3) Selection

Selection in genetic algorithms plays the same role as natural selection. It follows the survival Darwinian principle of those most adapted, it decide what are the individuals that survive and which ones disappear, this selection is according to their fitness functions. a Population called intermediate is then formed by selected individuals.

There are several methods of selection. We mention two of the best known:

- Lottery roulette Method ;
- Tournament Method.

4) Crossover

Crossing enables a pair of individuals among those selected, to share their genetic information e. d. their genes. Its principle is simple: two individuals are randomly taken, and they are called "parents", then we draw a random "P" number in the interval [0, 1], after that it will be compared to some crossing probability "Pc".

- If $P > P_c$, there will be no crossing, and the parents are copied into a new generation.
- If else; $P \leq P_c$, crossing occurs and the chromosomes parents are crossed to produce tow children replacing their parents in the next generation.

There are different crossing types, the most known are:

- The multipoint crossover
- The uniforme crossover

5) Mutation

The mutation operator enables to explore new points in the search space and ensures the possibility to leave local optima; mutation applies to each individual gene with a mutation probability (Pm) following the same crossing principle.

- If $P > P_m$, there will be no mutation will and the gene remains as it is.
- If $P \leq P_m$ mutation occurs, and the gene will replaced with another gene randomly drawn among the possible values. In the case of a binary coding, it is simply to replace a "0" by a "1" and vice versa.

6) Terminaison criteria

As in any iterative algorithm, we must define a stopping criteria, this can be formulated in various ways, among which we can mention:

- Stop the algorithm when the result reached a satisfactory solution;

- Stop if there is no improvement for some number of generations;
- Stop if a certain number of generations is exceeded.

Example:

We consider the simple case of function with one variable "x" belonging to the natural numbers set:

$$\text{Maximise } F_{obj} = 4 \sin(x) + x$$

$$\text{Subject to } 0 < x \leq 30$$

The used parameters:

- A 8 bits binary encoding ;
- The search interval [0,30] ;
- A Lottery roulette Method;
- A simple crossing (to one point),with crossing probability Pc=0.7 ;
- A mutation probability Pm=0.1.

To run and view the various steps of genetic algorithm, we created and developed a "GUI" (Graphical User Interfaces) in MATLAB software, this latter allows:

- To calculate and display the AG operations (Coding and initialization, Evaluation, Selection, Crossing and mutation);
- To display graphically the problem solution, as is shown in figure 5.

Fig. 5. Optimization result

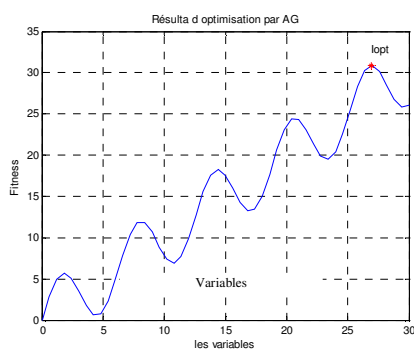

The problem

solution:

$$x = 26.9412. \quad F(x) = 30.8288$$

The various operations are developed by the realized "GUI" (shown in figure 6).

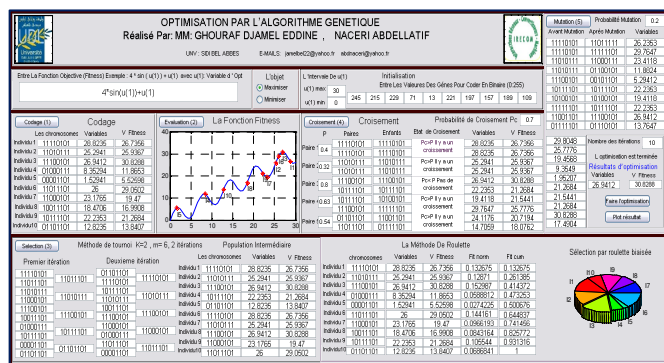

Fig. 6. The genetic algorithm optering developed under GUI/MATLAB

IV. APPLICATION OF THE ALGORITHM GENETIC TO OPTIMEZED AVR-PSS

A) The Linear System Stability -analytical study

Recall that the damping factor ζ of method represented by its complex eigenvalue " λ " is given by:

$$\zeta = \frac{-\sigma}{\sqrt{\sigma^2 + \omega^2}} \quad (3)$$

$$\text{With } \lambda = \sigma \pm j\omega \quad (4)$$

A damping factor ζ leads to a significant well-damped dynamic response; all eigenvalues must be located in the left area of the complex plane defined by two half-lines. For a critical value of the damping factor ζ_{cr} : we impose a relative stability margin [10].

The real part of the eigenvalue σ determines the rapid decay / growth exponential dynamic response of the component system. Thus, σ very negative results in a fast dynamic response. To do this, all the eigenvalues must be located in the left area of the complex plane defined by a vertical through a critical value of the portion real (σ_{cr} : we defined as the absolute stability margin when setting the parameters of PSS, it is desirable that these two criteria are taken into account for proper regulation. The combination between these two criteria leads to an area called D; stability area [11], show in figure 7. Moving eigenvalues in this area ensures robust performance for a large number of points operated [12].

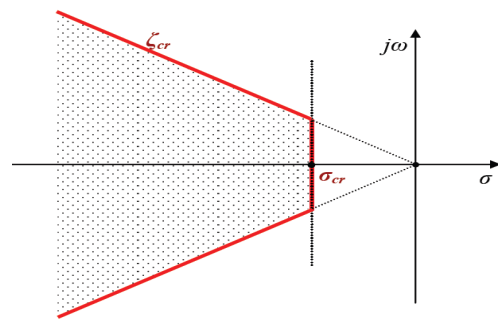

Fig. 7. D. Stability area

B) objective function

The purpose of the PSS use is to ensure satisfactory oscillations damping, and ensure the overall system stability to different operation points. To meet this goal, we using a function composed of two multi-objective functions [13]. This function must maximize the stability margin by increasing damping factors while minimizing the system real eigenvalues. Therefore, all eigenvalues are in the D stability area, the multi-objective function calculating steps are:

- 1-formulate the linear system in an open -loop (without PSS);
- 2-locate the PSS and its parameters initialized by the G.A through an initial population;
- 3- Calculate the closed loop system eigenvalues and take only the dominant modes: $\lambda = \sigma \pm j\omega$

- 4- Find the system eigenvalues real parts (σ) and damping factor ζ ;
 - 5- Determine the (ζ) minimum value and the ($-\sigma$) maximum value, which can be formulated respectively as: (minimum (ζ)) and (maximum $-\sigma$);
 - 6- Gather both objective functions in a multi-objective function F as follows:
 $F_{obj} = -\max(\sigma) + \min(\zeta)$
 - 7- Return this Multi-objective function value to the AG program to restart a new generation.
- Figure 8 shows the proposed in this paper the GA for the AVR-PSS parameters optimization.

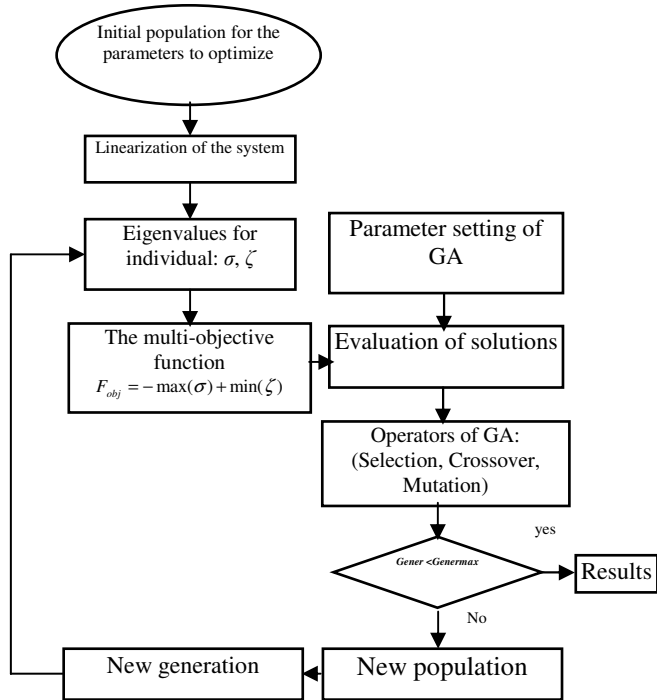

Fig. 8. The multi-objective function and AG program Flowchart for the PSS

The optimized parameters for PSS are: K_{PSS} , T_w , T_1 , and T_2

- With:
- $5 \leq K_{PSS} \leq 150$ Number of Individuals = 120
 - $0.01 \leq T_w \leq 0.05$ Maximum Generation = 100
 - $0.01 \leq T_1 \leq 0.06$ A crossing probability $P_c = 0.7$
 - $0.01 \leq T_2 \leq 0.065$ A mutation probability $P_m = 0.01$

Table 1 give a simulation result optimized PSS parameters with different SG

TABEL1. THE PSS OPTIMIZED PARAMETERS

parameters	TBB-200	TBB-500	BBC-720	TBB-1000
T_w	0.0321	0.029	0.0445	0.0234
T_1	0.054	0.0322	0.0356	0.0214
T_2	0.074	0.011	0.034	0.0142
K_{PSS}	51.43	15.45	100.548	15.506

V. THE SIMULATION RESULT UNDER GUI/MATLAB

A) Creation of a calculating code under MATLAB / SIMULINK

The “SMIB” system used in our study includes:

- A synchronous generator (SG) ;
- Tow voltage regulators: AVR and AVR-PSS connected to;
- A Power Infinite network line

We used for our simulation in this paper, the SMIB mathematical model based on permeances networks model cullled PARK-GARIOV [14], and shown in Figure 9 [14].

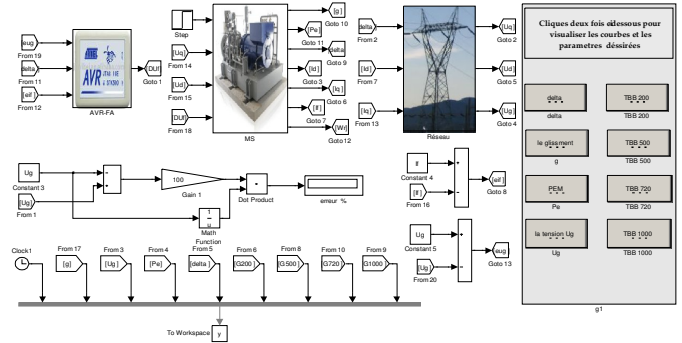

Fig. 9. Structure of the synchronous generator (PARK-GARIOV model) with the excitation controller under [14].

A) A Created GUI/MATLAB for Optimization using GA

To analyzed and visualized the different dynamic behaviors we have creating and developing a “GUI” (Graphical User Interfaces) under MATLAB .This GUI allows as to:

- Perform control system from PSS controller;
- To optimized the controller parameters by AG;
- View the system regulation results and simulation;
- Calculate the system dynamic parameters ;
- Test the system stability and robustness;
- Study the different operating regime (under-excited, rated and over excited regime).

The different operations are performed from GUI realized under MATLAB and shown in Figure 10.

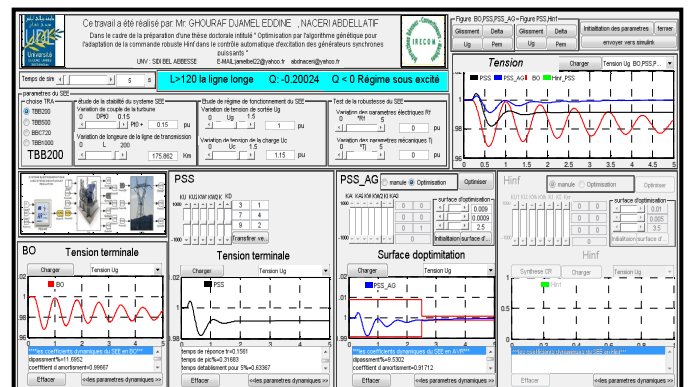

Fig. 10. The realised GUI / MATLAB

C) Simulation result and discussion

The following results (Table 2 and Figure 11, 12) were obtained by studying the "SMIB" static and dynamic performances in the following cases:

1. SMIB in open loop (without regulation) (OL)
2. Closed Loop System with the regulator AVR and conventional stabilizer PSS-FA [14].
- 3 - Optimization of Regulators PSS-AVR using genetic algorithm (PSS-OPT) parameters.

We simulated three operating: the under-excited, the rated and the over-excited.

Our study is interested in the Powerful Synchronous Generators of type: TBB-200, TBB-500 BBC-720, TBB-1000 (parameters in Appendix 2) [14].

Table 2 shows the dominant modes eigenvalues , for more details about the calculating parameters see GUI-MATLAB in the Appendix 3 created.

Table 3 presents the TBB -200 static and dynamic performances results in (OL) and (CL) with PSS and PSS-optimized, for an average line ($X_e = 0.3$ pu), and an active power $P=0.85$ p.u.

Where: α : eigenvalues real parts ε %: the static error, $d\%$: the maximum overshoot, t_s : the setting time

TABLE II. THE EIGENVALUES OF THIS SYSTEM

Q	Eigenvalues		
	λ OL	λ PSS	λ PSS-OPT
-0.1372	instable	-1.6201 ± 4.3629i	-2.3283 ± 3.3747i
-0.4571	instable	-1.6503 ± 4.3582i	-2.3463 ± 3.9866i
0.1896	-0.0813 ± 7.2567i	-1.6865 ± 5.2802i	-2.3906 ± 2.9698i
0.3908	-0.1271 ± 7.9143i	-1.5379 ± 5.9476i	-2.3906 ± 2.9698i
0.5078	-0.1451 ± 8.2203i	-0.9432 ± 5.0531i	-1.9582 ± 3.2602i
0.6356	-0.1588 ± 8.5134i	-0.9283 ± 5.3747i	-1.9803 ± 3.5592i

TABLE III. THE "SMIB" STATIC AND DYNAMIC PERFORMANCES

Q	Eigenvalues real parts				The static error			
	OL	AVR	PSS	PSS-OPT	OL	AVR	PSS	PSS-GA
-0.1372	Unstable	-0.709	-1.6201	-2.3283	instable	-2.640	-1.620	-1.234
-0.4571	Unstable	-0.708	-1.6503	-2.3463	instable	-2.673	-1.629	-1.241
0.1896	-0.0813	-0.791	-1.6865	-2.3906	-5.038	-2.269	-1.487	-1.267
0.3908	-0.1271	-0.634	-1.5379	-2.3906	-5.202	-1.807	-1.235	-1.129
0.5078	-0.1451	-0.403	-0.9432	-1.9582	-3.777	-0.933	-0.687	-0.604
0.6356	-0.1588	-0.396	-0.9283	-1.9803	-3.597	-0.900	-0.656	-0.567
The setting time for 5%				The maximum overshoot %				
Q	OL	AVR	PSS	PSS-OPT	OL	AVR	PSS	PSS-GA
-0.1372	Unstable	4,231	1,704	1,349	9,572	9,053	7,892	7,237
-0.4571	Unstable	4,237	1,713	1,323	9,487	9,036	7,847	7,219
0.1896	-	3,793	1,617	1,408	10,959	9,447	8,314	7,928
0.3908	-	4,732	1,706	1,630	10,564	8,778	7,883	7,659
0.5078	14,320	7,444	2,041	1,877	9,402	6,851	6,588	6,269
0.6356	14,423	7,576	2,080	1,801	9,335	6,732	6,463	6,012

In the Figures 11 and 12 show an example of simulation result with respectively: 'Ug' the stator terminal voltage; 'Pe' the electromagnetic power system, 's' variable speed, 'delta' The internal angle TBB200 of Turbo-generator with $P = 0.85$, $X_e = 0.5$, $Q1 = -0.1372$ (pu)

From the simulation results, it can be observed that the use of PSS optimized by AG improves considerably the dynamic performances (static errors negligible so better precision, and very short setting time so very fast system., and we found that

after few oscillations, the system returns to its equilibrium state even in critical situations (specially the under-excited regime) and granted the stability and the robustness of the studied system.

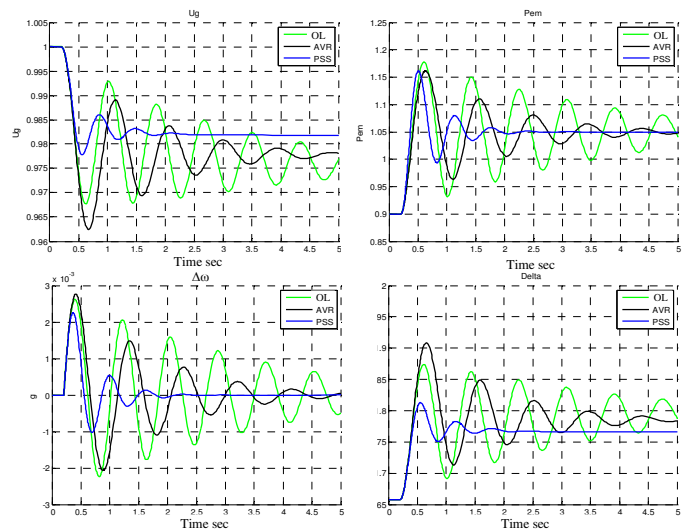

Fig. 11. functioning system in the under-excited of TBB 200 connected to a long line with AVR ,OL and PSS

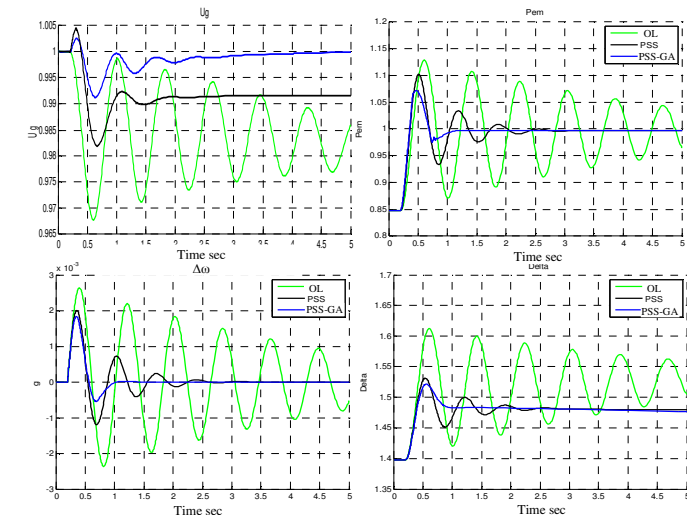

Fig. 12. functioning system in the under-excited used of TBB 200 connected to a long line with PSS , PSS- AG and OL

VI. CONCLUSION

In this article, we have optimized the PSS parameters by genetic algorithms; these optimized PSS are used for powerful synchronous generators exciter voltage control in order to improve static and dynamic performances of power system.

This technique (GA) allows us to obtain a considerable improvement in dynamic performances and robustness stability of the SMIB studied.

All results are obtained by using our created GUI/MATLAB.

REFERENCES

[1] LA. GROUZDEV, A.A. STARODEBSEV, S.M. OUSTINOV "Conditions for the application of the best amortization of transient

processes in energy systems with numerical optimization of the controller parameters AVR-FA" Energy-1990-N ° II-pp.21-25 (translated from Russian).

[2] DEMELLO F.P., FLANNETT L.N. and UNDRILL J.M., « Practical approach to supplementary stabilizing from accelerating power », IEEE Trans., vol. PAS-97, pp. 1515-1522, 1978.

[3] DEMELLO F.P. and CONCORDIA C., « Concepts of synchronous machine stability as affected by excitation control », IEEE Trans. on PAS, vol. PAS-88, pp. 316-329, 1969.

[4] S.V. SMOLOVIK « mathematical modeling Method of transient processes synchronous generators most usual and non-traditional in the electro-energy systems "PhD Thesis State, Leningrad Polytechnic Institute, 1988 (translated from Russian).

[5] P. KUNDUR, "Definition and Classification of power System Stability", Draft 2, 14 January, 2002

[6] J.H. HOLLAND, "Adaptation in Natural and Artificial Systems," University of Michigan Press, 1975.

[7] P.M. ANDERSON, A. A. FOUAD "Power System control and Stability", IEE Press, 1991.

[8] HONG Y.Y. and WU W.C., « A new approach using optimization for tuning parameters of power system stabilizers », IEEE Transactions on Energy Conversion, vol. 14, n°. 3, pp. 780-786, Sept. 1999.

[9] R. ASGHARIAN "Asymptomatic approach to performance weights selection in design of robust H ∞ PSS using genetic algorithms", IEEE trans. on EC, vol 11, No 21, September 1996, pp.111-11

[10] ALLENBACH J.M., "Automated Systems", Volume 1, classical linear Enslavements, Engineering School of Geneva, 2005.

[11] YEE S.K. and MILANOVIĆ J.V., « Comparison of the optimization and linear sequential method for tuning of multiple PSSs ». IEEE Power Engineering Society, General Meeting Denver, CO, June. 2004.

[12] SINGH R., "A Novel Approach for Tuning of Power System Stabilizer Using Genetic Algorithm," Ph.D. Thesis, Faculty of Engineering, Indian Institute of Science, Bangalore, July 2004.

[13] HASAN ALKhatib "Study of stability for small disturbances in great electrical networks :optimization of cntrol by a metaheuristic method" Ph.D. Thesis, Paul Cézanne University Aix-Marseille, 2008.

[14] GHOURAF D.E., "Study and Application of the advanced frequency control techniques in the voltage automatic regulator of synchronous machines", Magister Thesis, UDL-SBA, 2010 (In French).

APPENDIX

1. Parameters of the used Turbo –Alternators

Parameters	TBB-200	TBB-500	BBC-720	TBB1000	Units of measure
power nominal	200	500	720	1000	MW
Factor of power nominal	0.85	0.85	0.85	0.9	p.u.
X_d	2.56	1.869	2.67	2.35	p.u.
X_q	2.56	1.5	2.535	2.24	p.u.
X_s	0.222	0.194	0.22	0.32	p.u.
X_f	2.458	1.79	2.587	2.173	p.u.
X_{sf}	0.12	.115	0.137	0.143	p.u.
X_{sfd}	0.0996	0.063	0.1114	0.148	p.u.
X_{sf1q}	0.131	0.0407	0.944	0.263	p.u.
X_{sf2q}	0.9415	0.0407	0.104	0.104	p.u.
R_a	0.0055	0.0055	0.0055	0.005	p.u.
R_f	0.000844	0.000844	0.00176	0.00132	p.u.
R_{1d}	0.0481	0.0481	0.003688	0.002	p.u.
R_{1q}	0.061	0.061	0.00277	0.023	p.u.
R_{2q}	0.115	0.115	0.00277	0.023	p.u.

2. Power System model:

- Curreants equations:

$$I_d = \frac{U_q - E_q''}{X_d''} I_d = -\frac{(U_d - E_d'')}{X_q''} I_f = \frac{(\Phi_f - \Phi_{ad})}{X_{sr}}$$

$$I_{1d} = \frac{(\Phi_{1d} - \Phi_{ad})}{X_{srd}} I_{1q} = \frac{(\Phi_{1q} - \Phi_{aq})}{X_{sr1q}} I_{2q} = \frac{(\Phi_{2q} - \Phi_{aq})}{X_{sr2q}}$$

$$E_q'' = \frac{1/X_{sf} \cdot X_f \cdot E_q' + 1/X_{sfd} \cdot X_{fd} \cdot E_{fd}'}{1/X_{ad} + 1/X_{sf} + 1/X_{sfd}} E_d'' = \frac{1/X_{sfq} \cdot X_{fq} \cdot E_{fd}'}{1/X_{ad} + 1/X_{sfq}}$$

- Flow equations:

$$\Phi_{ad} = E_q'' + (X_d'' - X_s) I_d, \Phi_{aq} = E_d'' + (X_q'' - X_s) I_q$$

$$\Phi_{1q} = \omega_s \int_0^{t_q} (-R_{1q} I_{1q}) dt, \Phi_{2q} = \omega_s \int_0^{t_{2q}} (-R_{2q} I_{2q}) dt$$

$$\Phi_f = \omega_s \int_0^{t_f} (-R_f I_f + U_{f0}) dt, \Phi_{1d} = \omega_s \int_0^{t_{1d}} (-R_{1d} I_{1d}) dt$$

- Mechanical equations

$$d\delta = (\omega - \omega_s) dt, s = \frac{\omega - \omega_s}{\omega_s}$$

$$M_T + M_j + M_e = 0 \quad \text{With} \quad \left(M_j = -j \frac{d\omega}{dt} \right)$$

$$T_j \frac{d}{dt} s + (\Phi_{ad} I_q - \Phi_{aq} I_d) = M_T \quad \text{ou} \quad T_j \frac{d}{dt} s = M_T - M_e$$

3. The PSS-AVR model

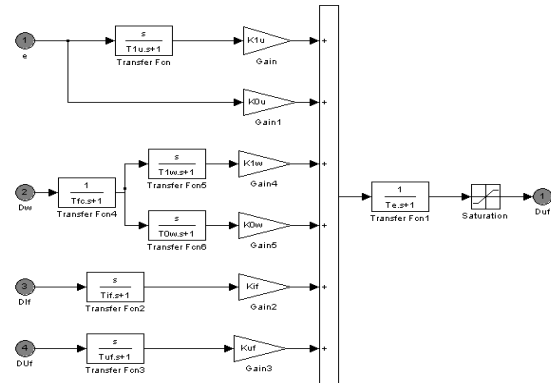

4. Dynamics parameters calculated through GUI-MATLAB

